



A62S6316 Series

Preliminary

64K X 16 BIT LOW VOLTAGE CMOS SRAM

Document Title

64K X 16 BIT LOW VOLTAGE CMOS SRAM

Revision History

<u>Rev. No.</u>	<u>History</u>	<u>Issue Date</u>	<u>Remark</u>
0.0	Initial issue	October 8, 1998	Preliminary
0.1	Change access times from 70/100 ns to 55/70 ns(max.) Change dynamic operating current from 80/70mA to 40mA Modify TSOP 44L (Type II) outline drawing	February 12, 1999	
0.2	Modify truth table	June 9, 1999	



A62S6316 Series

Preliminary

64K X 16 BIT LOW VOLTAGE CMOS SRAM

Features

- Operating voltage: 2.7V to 3.3V
- Access times: 55/70 ns (max.)
- Current:
 - A62S6316-S series: Operating: 40mA (max.)
Standby: 15µA (max.)
 - A62S6316-SI series: Operating: 40mA (max.)
Standby: 30µA (max.)
- Extended operating temperature range : -25°C to 85°C for -SI series
- Full static operation, no clock or refreshing required
- All inputs and outputs are directly TTL-compatible
- Common I/O using three-state output
- Data retention voltage: 2V (min.)
- Available in 44-pin TSOP and 48-ball Mini BGA (6X8) packages.

General Description

The A62S6316 is a low operating current 1,048,576-bit static random access memory organized as 65,536 words by 16 bits and operates on low power supply voltage from 2.7V to 3.3V. It is built using AMIC's high performance CMOS process. Inputs and three-state outputs are TTL compatible and allow for direct interfacing with common system bus structures.

The chip enable input is provided for POWER-DOWN, device enable. Two byte enable inputs and an output enable input are included for easy interfacing. Data retention is guaranteed at a power supply voltage as low as 2V.

Pin Configuration

■ TSOP (Type II)

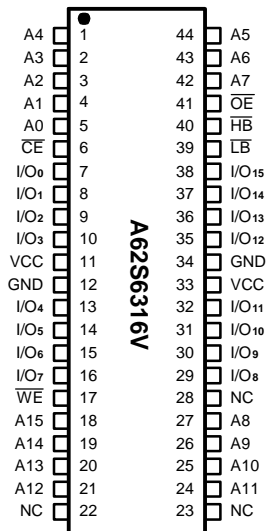

■ Mini BGA (6X8) Top View

	1	2	3	4	5	6
A	LB	OE	A0	A1	A2	NC
B	I/O ₈	HB	A3	A4	CS	I/O ₀
C	I/O ₉	I/O ₁₀	A5	A6	I/O ₁	I/O ₂
D	VSS	I/O ₁₁	NC	A7	I/O ₃	VCC
E	VCC	I/O ₁₂	NC	NC	I/O ₄	VSS
F	I/O ₁₄	I/O ₁₃	A14	A15	I/O ₅	I/O ₆
G	I/O ₁₅	NC	A12	A13	WE	I/O ₇
H	NC	A8	A9	A10	A11	NC

A62S6316G

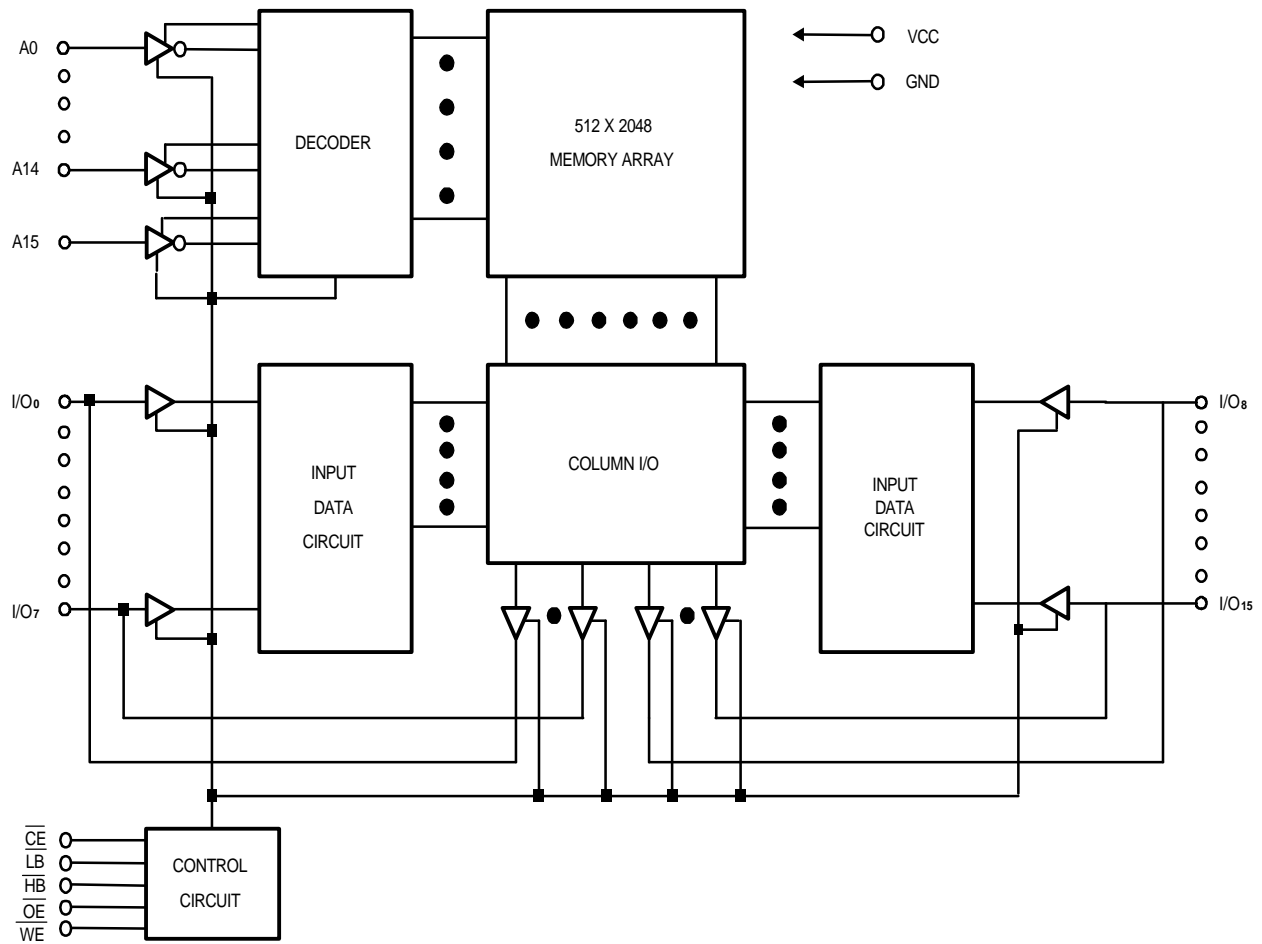
Block Diagram



Pin Description - TSOP

Pin No.	Symbol	Description
1 - 5, 18 - 21, 24 - 27, 42 - 44	A0 - A15	Address Inputs
6	\overline{CE}	Chip Enable Input
7 - 10, 13 - 16, 29 - 32, 35 - 38	I/O ₀ - I/O ₁₅	Data Input/Outputs
17	\overline{WE}	Write Enable Input
39	\overline{LB}	Byte Enable Input (I/O ₀ to I/O ₇)
40	\overline{HB}	Byte Enable Input (I/O ₈ to I/O ₁₅)
41	\overline{OE}	Output Enable Input
11, 33	VCC	Power
12, 34	GND	Ground
22 , 23, 28	NC	No Connection

Recommended DC Operating Conditions

(T_A = 0°C to + 70°C or -25°C to 85°C)

Symbol	Parameter	Min.	Typ.	Max.	Unit
VCC	Supply Voltage	2.7	3.0	3.3	V
GND	Ground	0	0	0	V
V _{IH}	Input High Voltage	2.2	-	VCC + 0.3	V
V _{IL}	Input Low Voltage	-0.3	-	+0.6	V
C _L	Output Load	-	-	30	pF
TTL	Output Load	-	-	1	-



Absolute Maximum Ratings*

VCC to GND -0.5V to +4.6V
 IN, IN/OUT Volt to GND -0.5V to VCC + 0.5V
 Operating Temperature, Topr -25°C to +85°C
 Storage Temperature, Tstg -55°C to +125°C
 Power Dissipation, Pr 0.7W
 Soldering Temp. & Time 260°C, 10 sec

***Comments**

Stresses above those listed under "Absolute Maximum Ratings" may cause permanent damage to this device. These are stress ratings only. Functional operation of this device at these or any other conditions above those indicated in the operational sections of this specification is not implied or intended. Exposure to the absolute maximum rating conditions for extended periods may affect device reliability.

DC Electrical Characteristics (TA = 0°C to +70°C or -25°C to 85°C, VCC = 2.7V to 3.3V, GND = 0V)

Symbol	Parameter	A62S6316-55S/70S		A62S6316-55SI/70SI		Unit	Conditions
		Min.	Max.	Min.	Max.		
<i>I</i> _{LI}	Input Leakage Current	-	1	-	1	μA	V _{IN} = GND to VCC
<i>I</i> _{LO}	Output Leakage Current	-	1	-	1	μA	$\overline{CE} = V_{IH}$ or $\overline{LB} = V_{IH}$ or $\overline{HB} = V_{IH}$ or $\overline{OE} = V_{IH}$ or $\overline{WE} = V_{IH}$ V _{I/O} = GND to VCC
<i>I</i> _{CC}	Active Power Supply Current	-	5	-	5	mA	$\overline{CE} = V_{IL}$, I _{I/O} = 0mA
<i>I</i> _{CC1}	Dynamic Operating Current	-	40	-	40	mA	Min. Cycle, Duty = 100% $\overline{CE} = V_{IL}$, I _{I/O} = 0mA
<i>I</i> _{CC2}		-	20	-	20	mA	$\overline{CE} = V_{IL}$, V _{IH} = VCC, V _{IL} = 0V, f = 1MHz, I _{I/O} = 0 mA
<i>I</i> _{SB}	Standby Power Supply Current	-	0.5	-	0.5	mA	$\overline{CE} = V_{IH}$
<i>I</i> _{SB1}		-	15	-	30	μA	$\overline{CE} \geq VCC - 0.2V$ V _{IN} ≥ 0V
V _{OL}	Output Low Voltage	-	0.4	-	0.4	V	I _{OL} = 2.1mA
V _{OH}	Output High Voltage	2.2	-	2.2	-	V	I _{OH} = -1.0mA



Truth Table

\overline{CE}	\overline{OE}	\overline{WE}	\overline{LB}	\overline{HB}	I/O ₀ to I/O ₇ Mode	I/O ₈ to I/O ₁₅ Mode	VCC Current
H	X	X	X	X	Not selected	Not selected	I _{SB1} , I _{SB}
L	L	H	L	L	Read	Read	I _{CC1} , I _{CC2} , I _{CC}
			L	H	Read	High - Z	I _{CC1} , I _{CC2} , I _{CC}
			H	L	High - Z	Read	I _{CC1} , I _{CC2} , I _{CC}
L	X	L	L	L	Write	Write	I _{CC1} , I _{CC2} , I _{CC}
			L	H	Write	Not Write/Hi - Z	I _{CC1} , I _{CC2} , I _{CC}
			H	L	Not Write/Hi - Z	Write	I _{CC1} , I _{CC2} , I _{CC}
L	H	H	L	X	High - Z	High - Z	I _{CC1} , I _{CC2} , I _{CC}
			X	L	High - Z	High - Z	I _{CC1} , I _{CC2} , I _{CC}
X	X	X	H	H	Not selected	Not selected	I _{SB1} , I _{SB}

Note: X = H or L

Capacitance (T_A = 25°C, f = 1.0MHz)

Symbol	Parameter	Min.	Max.	Unit	Conditions
C _{IN} *	Input Capacitance	-	6	pF	V _{IN} = 0V
C _{I/O} *	Input/Output Capacitance	-	8	pF	V _{I/O} = 0V

* These parameters are sampled and not 100% tested.



AC Characteristics (T_A = 0°C to +70°C or -25°C to 85°C, V_{CC} = 2.7V to 3.3V)

Symbol	Parameter	A62S6316-55S/SI		A62S6316-70S/SI		Unit
		Min.	Max.	Min.	Max.	
Read Cycle						
t _{RC}	Read Cycle Time	55	-	70	-	ns
t _{AA}	Address Access Time	-	55	-	70	ns
t _{ACE}	Chip Enable Access Time	-	55	-	70	ns
t _{BE}	Byte Enable Access Time	-	55	-	70	ns
t _{OE}	Output Enable to Output Valid	-	30	-	35	ns
t _{CLZ}	Chip Enable to Output in Low Z	10	-	10	-	ns
t _{BLZ}	Byte Enable to Output in Low Z	5	-	5	-	ns
t _{OLZ}	Output Enable to Output in Low Z	5	-	5	-	ns
t _{CHZ}	Chip Disable to Output in High Z	-	20	-	25	ns
t _{BHZ}	Byte Disable to Output in High Z	-	20	-	25	ns
t _{OHZ}	Output Disable to Output in High Z	-	20	-	25	ns
t _{OH}	Output Hold from Address Change	5	-	10	-	ns
Write Cycle						
t _{WC}	Write Cycle Time	55	-	70	-	ns
t _{CW}	Chip Enable to End of Write	50	-	60	-	ns
t _{BW}	Byte Enable to End of Write	50	-	60	-	ns
t _{AS}	Address Setup Time	0	-	0	-	ns
t _{AW}	Address Valid to End of Write	50	-	60	-	ns
t _{WP}	Write Pulse Width	40	-	50	-	ns
t _{WR}	Write Recovery Time	0	-	0	-	ns
t _{WHZ}	Write to Output in High Z	-	25	-	30	ns
t _{DW}	Data to Write Time Overlap	25	-	30	-	ns
t _{DH}	Data Hold from Write Time	0	-	0	-	ns
t _{OW}	Output Active from End of Write	5	-	5	-	ns

Note: t_{CHZ}, t_{BHZ} and t_{OHZ} and t_{WHZ} are defined as the time at which the outputs achieve the open circuit condition and are not referred to output voltage levels.

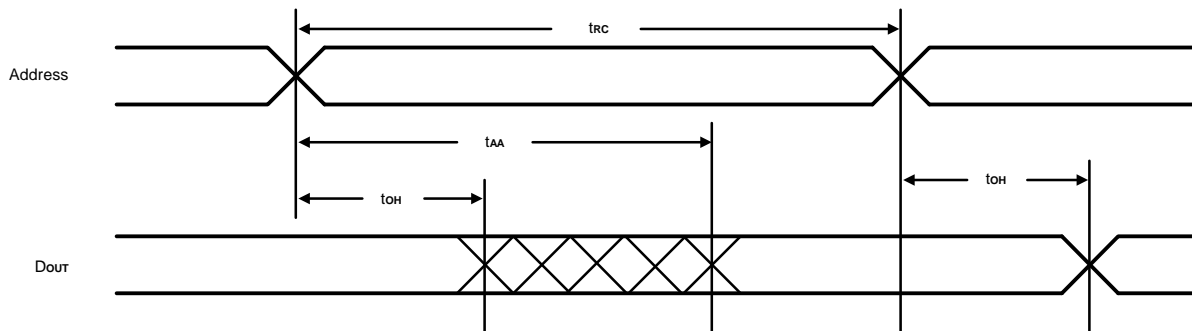
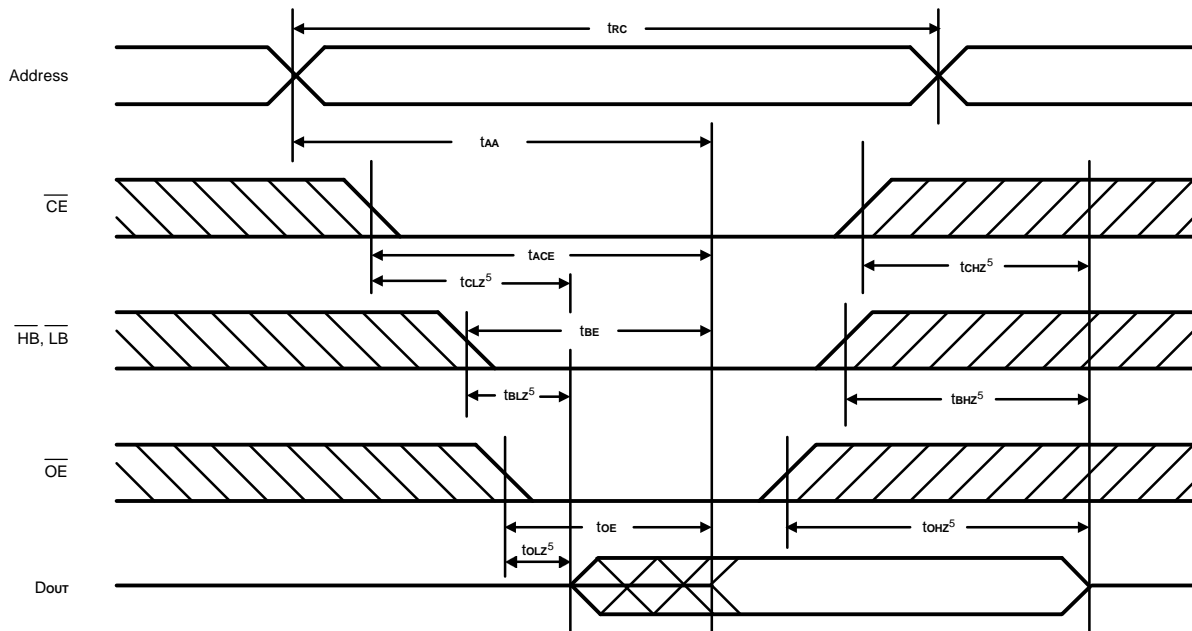
Timing Waveforms
Read Cycle 1^(1, 2, 4)

Read Cycle 2^(1, 2, 3)

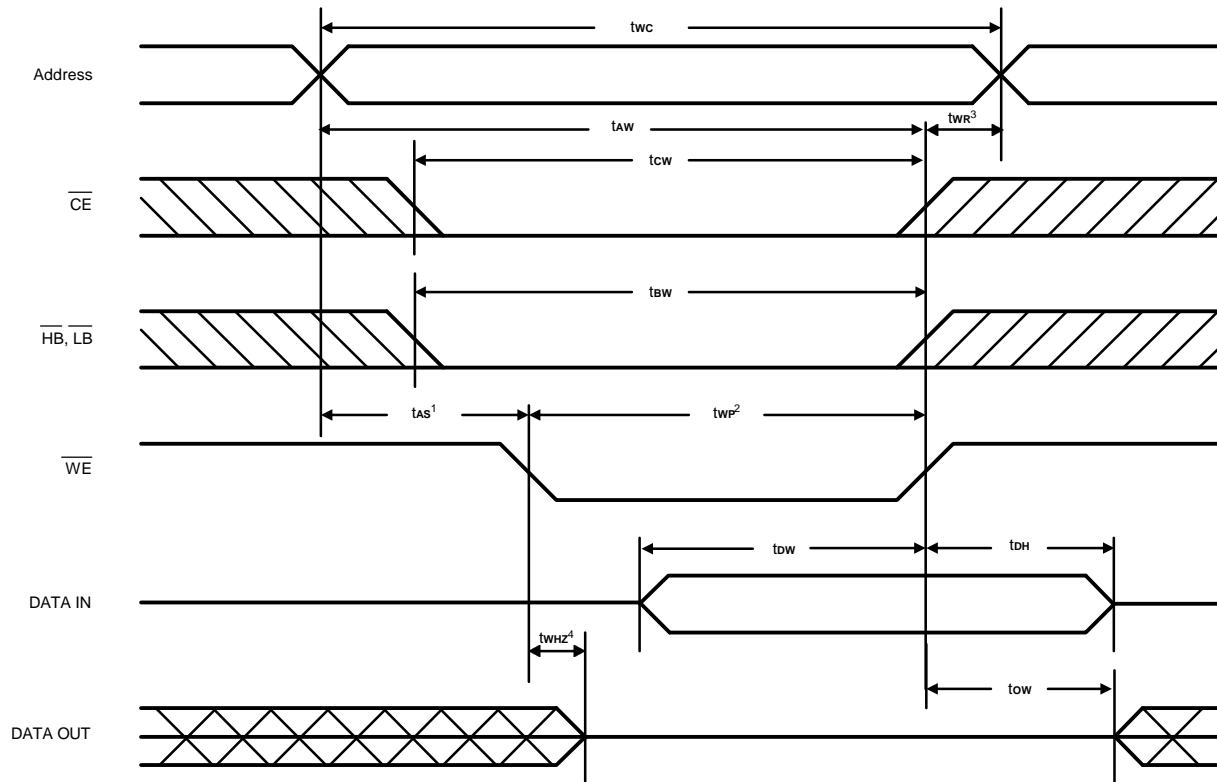
- Notes:
- \overline{WE} is high for Read Cycle.
 - Device is continuously enabled $\overline{CE} = V_{IL}$, $\overline{HB} = V_{IH}$ and, or $\overline{LB} = V_{IL}$.
 - Address valid prior to or coincident with \overline{CE} and (\overline{HB} and, or \overline{LB}) transition low.
 - $\overline{OE} = V_{IL}$.
 - Transition is measured $\pm 500\text{mV}$ from steady state. This parameter is sampled and not 100% tested.

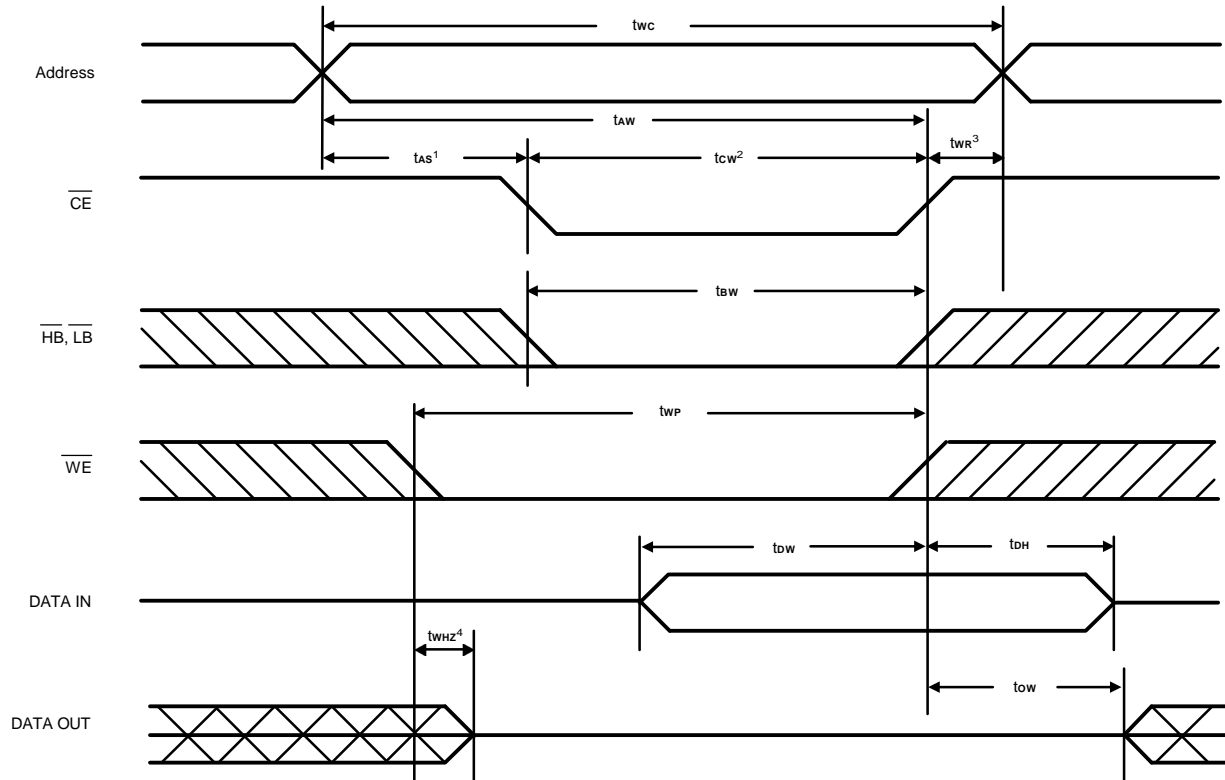
Timing Waveforms (continued)
**Write Cycle 1
(Write Enable Controlled)**

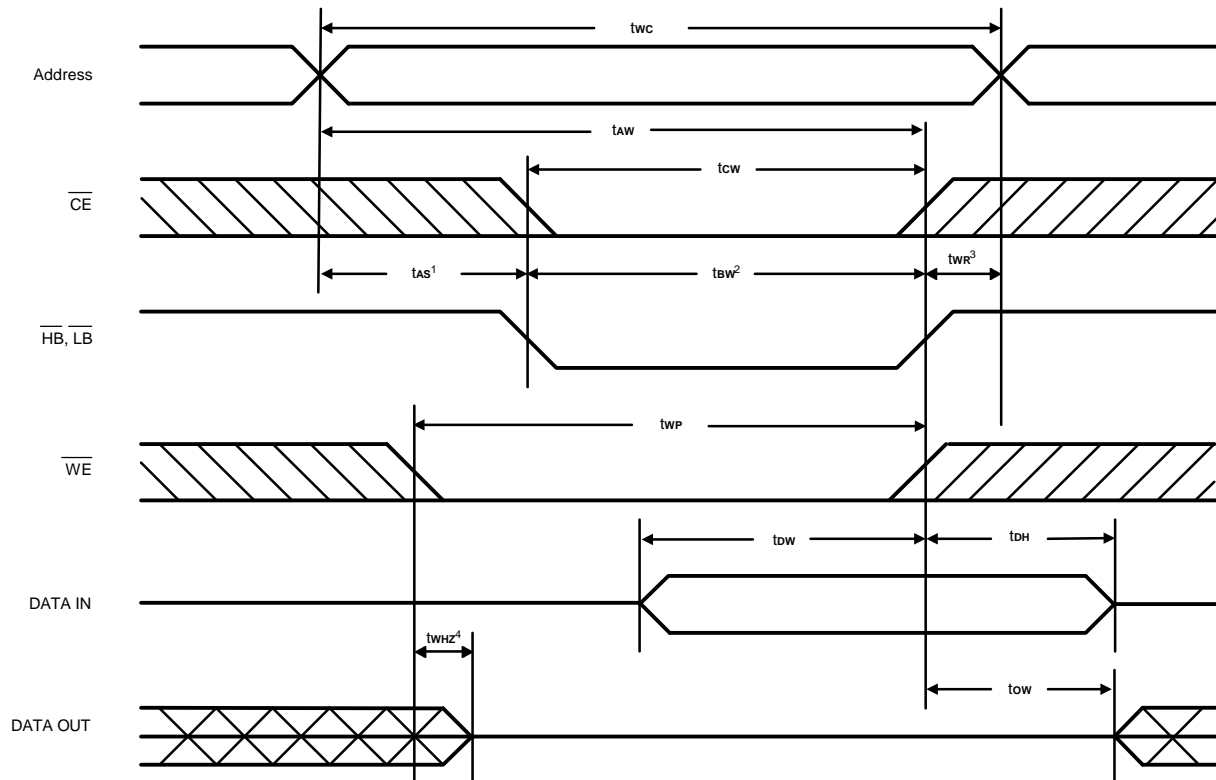
Timing Waveforms (continued)
**Write Cycle 2
(Chip Enable Controlled)**

Timing Waveforms (continued)
**Write Cycle 3
(Byte Enable Controlled)**

- Notes:
1. t_{as} is measured from the address valid to the beginning of Write.
 2. A Write occurs during the overlap (t_{wp} , t_{w}^2) of a low \overline{CE} , \overline{WE} and (\overline{HB} and/or \overline{LB}).
 3. t_{w}^3 is measured from the earliest of \overline{CE} or \overline{WE} or (\overline{HB} and/or \overline{LB}) going high to the end of the Write cycle.
 4. \overline{OE} level is high or low.
 5. Transition is measured $\pm 500\text{mV}$ from steady state. This parameter is sampled and not 100% tested.

AC Test Conditions

Input Pulse Levels	0V to 2.4V
Input Rise And Fall Time	5 ns
Input and Output Timing Reference Levels	1.5V
Output Load	See Figures 1 and 2

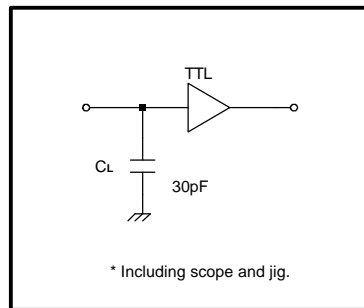
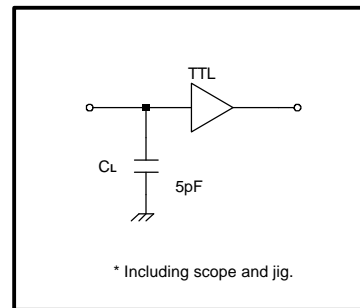
Figure 1. Output Load

Figure 2. Output Load for t_{CLZ}, t_{OLZ}, t_{CHZ}, t_{OHZ}, t_{WHZ}, and t_{OW}
Data Retention Characteristics (T_A = 0°C to 70°C or -25°C to 85°C)

Symbol	Parameter	Min.	Max.	Unit	Conditions	
V _{DR}	VCC for Data Retention	2.0	3.3	V	$\overline{CE} \geq VCC - 0.2V$	
I _{CCDR}	Data Retention Current	S-Version	-	10*	μA	VCC = 2.0V, $\overline{CE} \geq VCC - 0.2V$ V _{IN} ≥ 0V
		SI-Version	-	20**		
t _{CDR}	Chip Disable to Data Retention Time	0	-	ns	See Retention Waveform	
t _R	Operation Recovery Time	T _{RC}	-	ns		
t _{VR}	VCC Rise Time from Data Retention Voltage to Operating Voltage	5	-	ms		

* A62S6316-55S/70S

I_{CCDR}: max. 3μA at T_A = 0°C to + 40°C

** A62S6316-55SI/70SI

I_{CCDR}: max. 3μA at T_A = 0°C to + 40°C

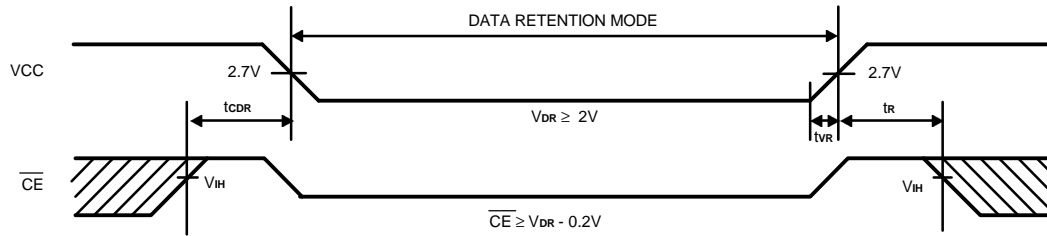
Low VCC Data Retention Waveform

Ordering Information

Part No.	Access Time (ns)	Operating Current Max. (mA)	Standby Current Max. (μ A)	Package
A62S6316V-55S	55	40	15	44L TSOP
A62S6316V-55SI		40	30	44L TSOP
A62S6316G-55S		40	15	48B Mini BGA
A62S6316G-55SI		40	30	48B Mini BGA
A62S6316V-70S	70	40	15	44L TSOP
A62S6316V-70SI		40	30	44L TSOP
A62S6316G-70S		40	15	48B Mini BGA
A62S6316G-70SI		40	30	48B Mini BGA

Package Information
TSOP 44L (Type II) Outline Dimensions

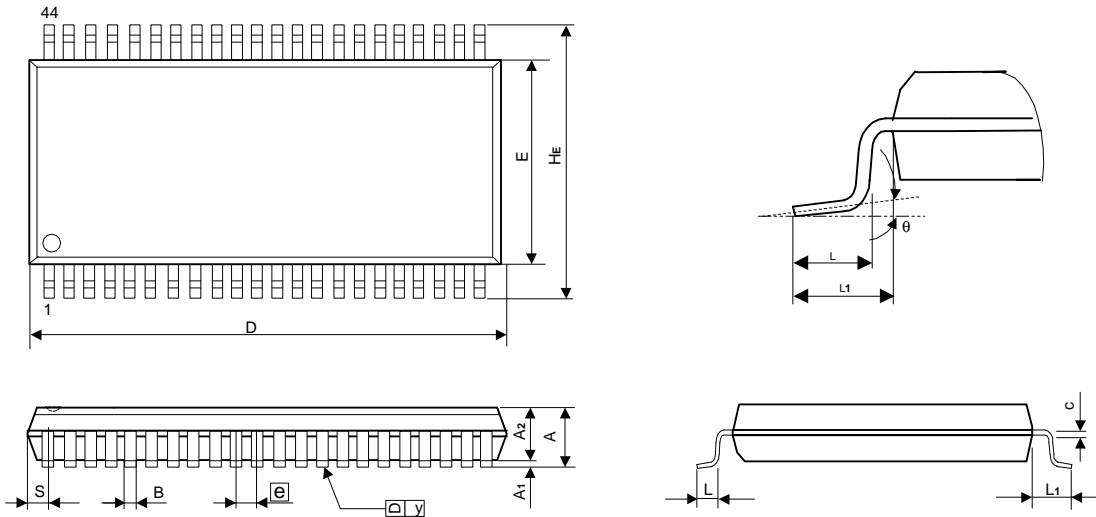
unit: inches/mm



Symbol	Dimensions in inches			Dimensions in mm		
	Min	Nom	Max	Min	Nom	Max
A	-	-	0.047	-	-	1.20
A1	0.002	-	0.006	0.05	-	0.15
A2	0.037	0.039	0.041	0.95	1.00	1.05
B	0.013	0.015	0.017	0.32	0.37	0.42
c	0.003	0.005	0.009	0.08	0.13	0.23
D	0.720	0.725	0.730	18.28	18.41	18.54
E	0.395	0.400	0.405	10.03	10.16	10.29
e	0.031 BSC			0.80 BSC		
HE	0.455	0.463	0.471	11.56	11.76	11.96
L	0.016	0.020	0.024	0.40	0.50	0.60
L1	-	0.031	-	-	0.80	-
S	-	-	0.035	-	-	0.90
y	-	-	0.004	-	-	0.10
θ	1°	3°	5°	1°	3°	5°

Notes:

1. The maximum value of dimension D includes end flash.
2. Dimension E does not include resin fins.
3. Dimension S includes end flash.

Package Information
Mini BGA 6X8 (48 BALLS) Outline Dimensions

unit : millimeter(mm)

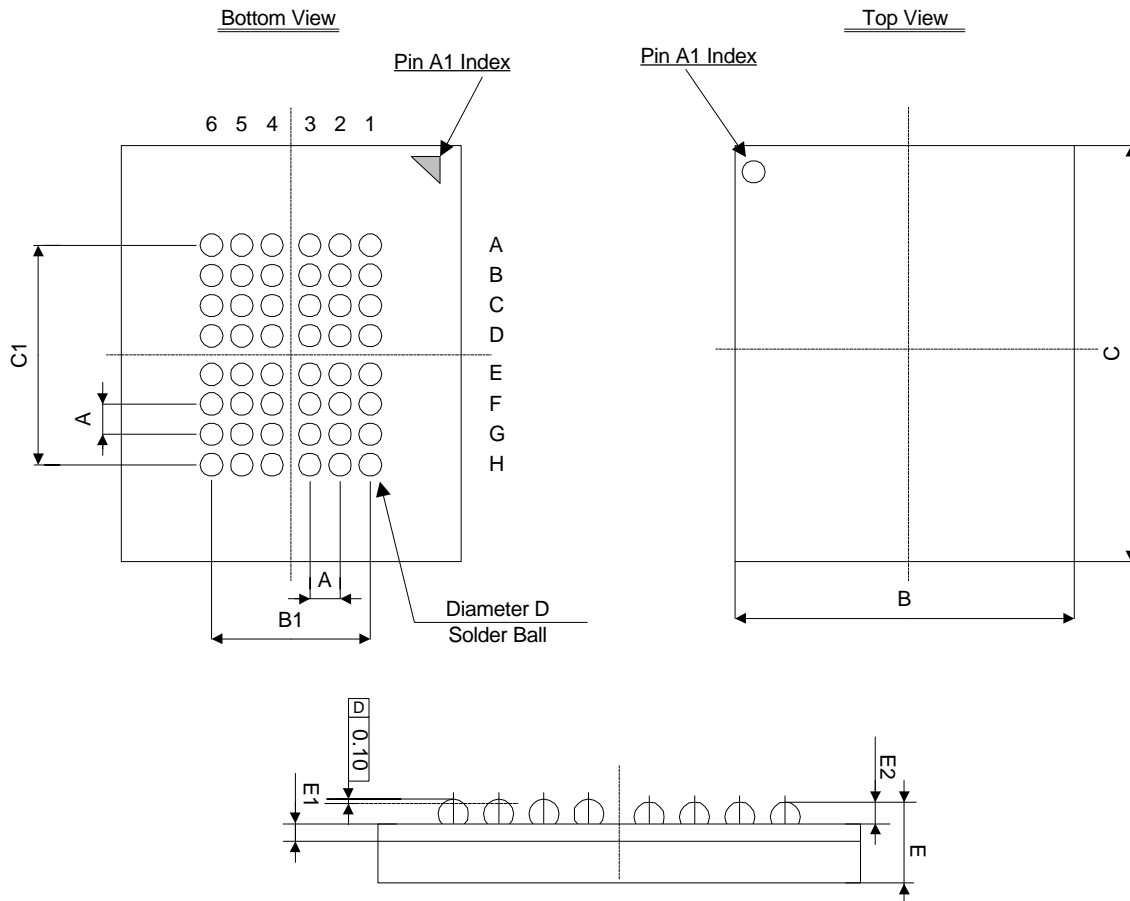

Symbol	Min	Typ	Max
A	-	0.75	-
B	5.90	6.00	6.10
B1	-	3.75	-
C	7.90	8.00	8.10
C1	-	5.25	-
D	0.30	0.35	0.40
E	1.00	1.10	1.20
E1	-	0.36	-
E2	-	0.22	-